

GLIDELINE

GS15 SLIDING DOOR

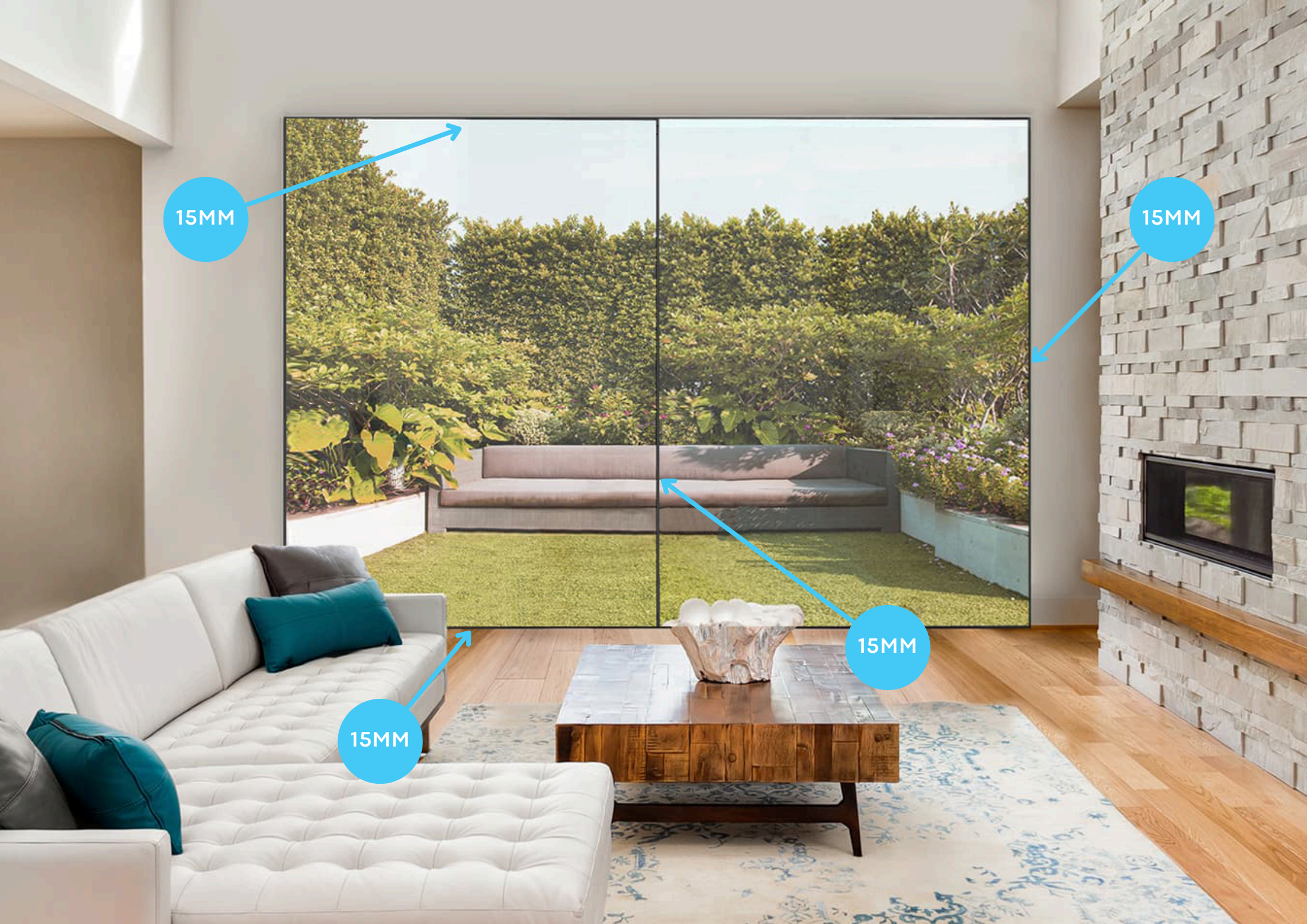



15MM

15MM

15MM

15MM

SPECIFICATION



CONFIGURATIONS

2 TRACK, 3 TRACK, QUAD TRACK

SIGHTLINES

INTERLOCK 15 MM

GLAZING

MAX. 30 MM, MIN. 26 MM DOUBLE GLAZED

MAXIMUM SASH DIMENSIONS

WIDTH (L) 2500 MM, HEIGHT (H) 3000 MM

MAXIMUM SASH WEIGHT

320 KG

COLOUR

POWDER COATING RAL FINISH
STANDARD 7016M, 9005M, 9016G
AVAILABLE IN 150+ RAL FINISHES
TEXTURED FINISH AVAILABLE
SPLIT COLOR FOR INTERIOR/EXTERIOR
WOOD EFFECT POWDER COATING
ANODIZED ALUMINIUM

BFRC Rating

kWh/(m²·yr)

≥20	A ++
>10 to 20	A +
0 to <10	A ✓
-10 to <0	B
-20 to <-10	C
-30 to <-20	D
-50 to <-30	E

FEATURES

Transmittance		Uw ≥ 1.2 (W/m ² K)
Acoustic insulation		Rw up to 41 dB
Air permeability		Class 4
Water tightness		Class 7A
Wind resistance		Class C5

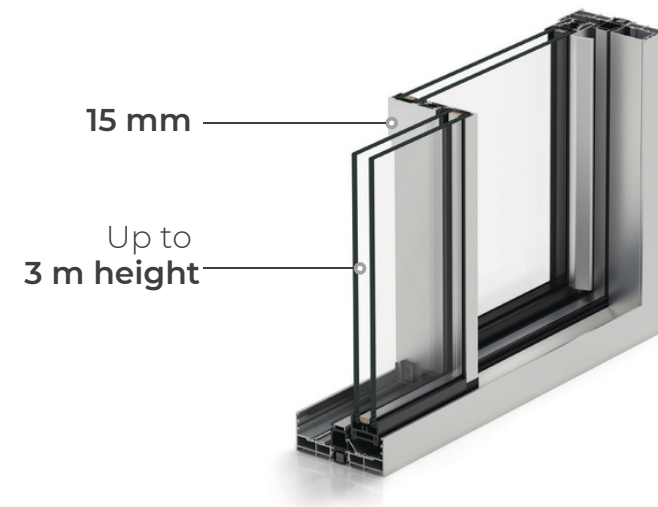

CONFIGURATIONS



2 PANE

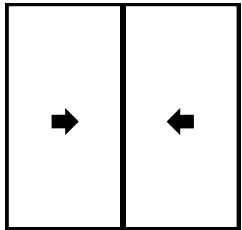

3 PANE

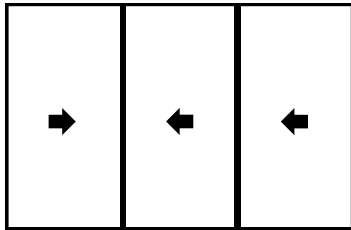

4 PANE

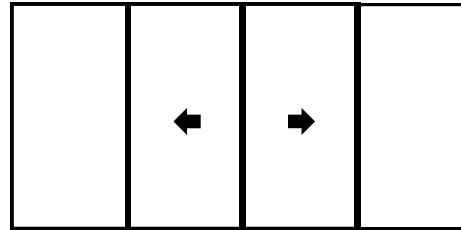

QUAD TRACK

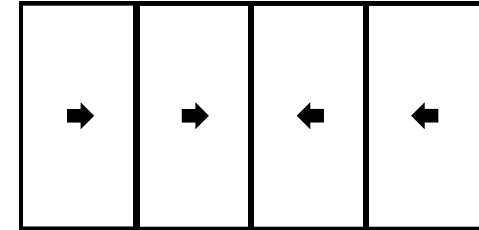

1 PANE POCKET

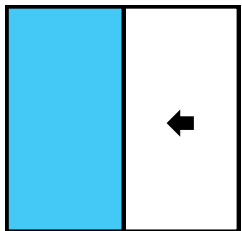

2 PANE POCKET

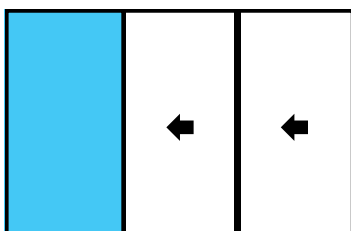

2 PANE POCKET

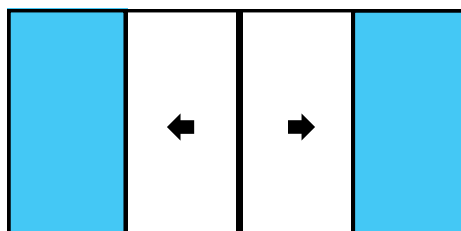

3 PANE POCKET

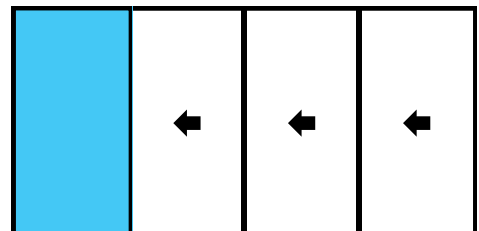

CORNER DOOR
MOVABLE CORNER POST OR
FRAMELESS BONDED CORNER

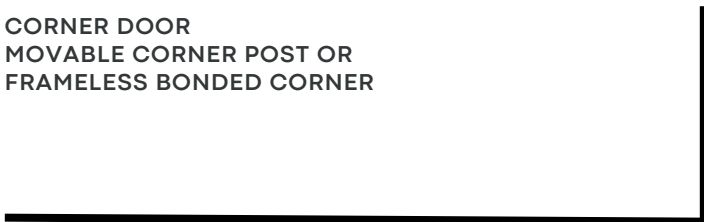

U SHAPE DOOR
MOVABLE CORNER POST OR
FRAMELESS BONDED CORNER

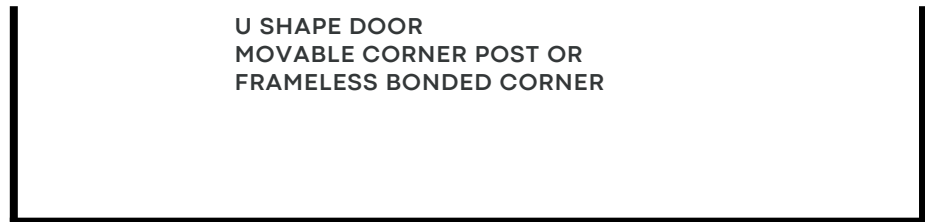

CONFIGURATIONS



HIDDEN TRACK SOLUTION

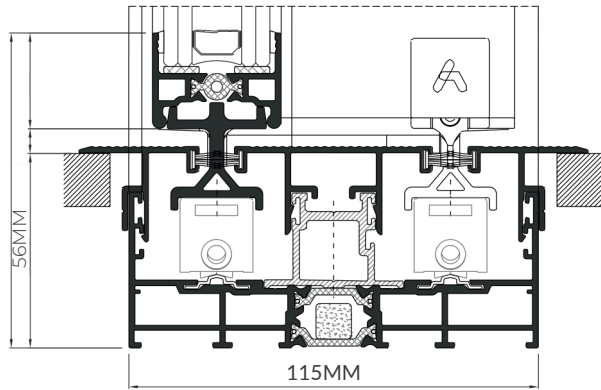

BESPOKE DRAINAGE SOLUTION

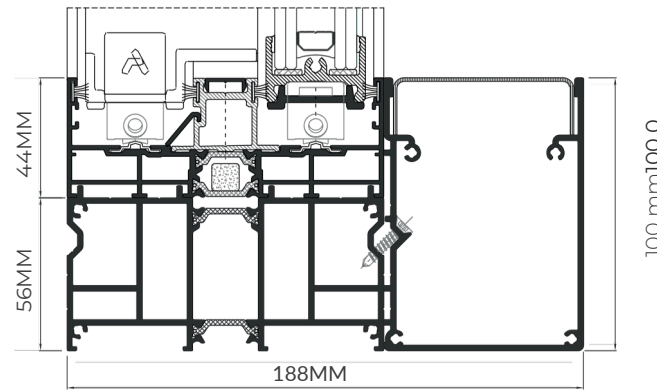

HIDDEN TRACK SOLUTION

15MM SIGHTLINE



3M MAX HEIGHT

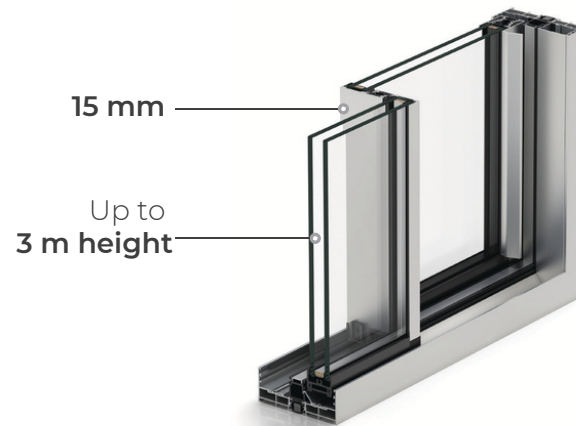

CONFIGURATIONS



15MM INTERLOCK



HIDDEN HANDLE DETAIL

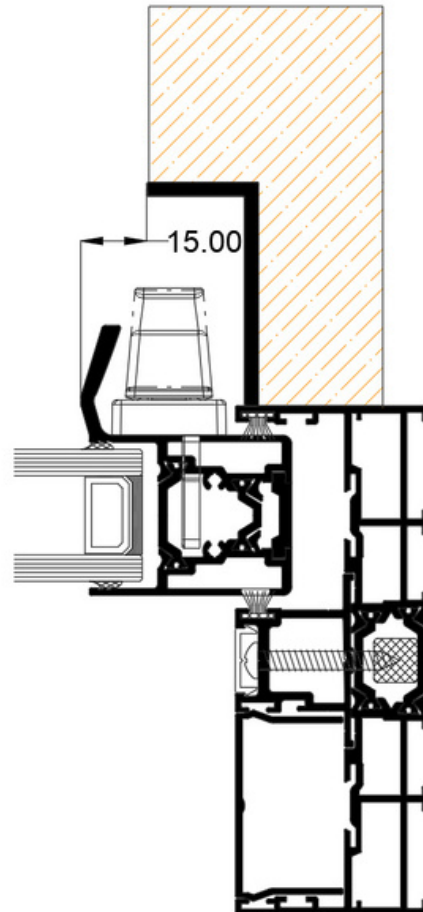

FLUSH STACKING

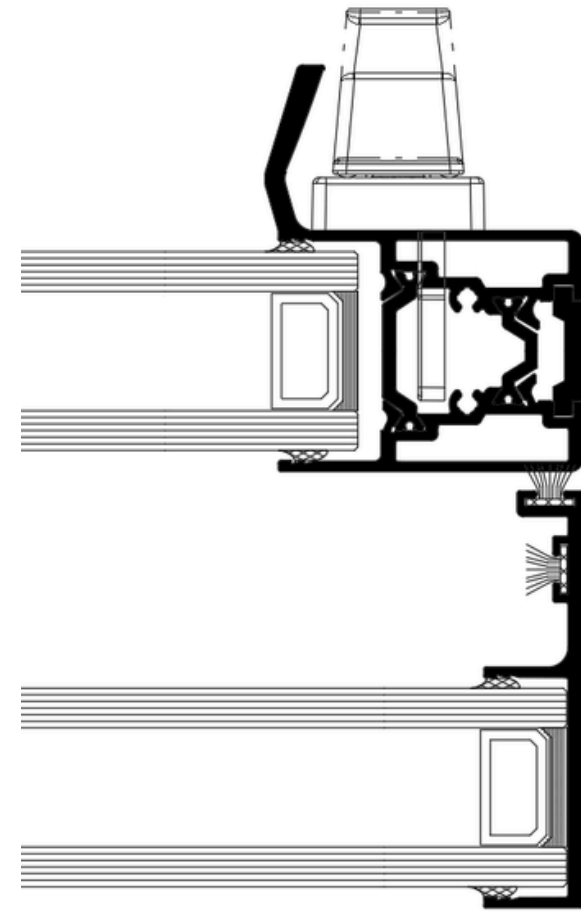

HARDWARE



GREY 7016



BLACK 9005



WHITE 9016



LIGHT SLIVER



DARK SLIVER



CUSTOM RAL

Thermally broken minimalist sliding system that provides maximum luminosity with a minimal aluminium interlock profile. It has an elegant design only 15 mm sightline and offers the possibility of an inlaid closing system and of hiding the frame and sash for truly unobstructed views.

The GS15 features a secure multipoint locking system that is operated with a simple up and down handle. The handle comes in a variety of colours to choose from as well as any RAL if you prefer to match the frame colour.



GLIDELINE GO

KEEP UP TO DATE WITH YOUR
GLAZING PROJECTS WITH
GLIDELINE GO

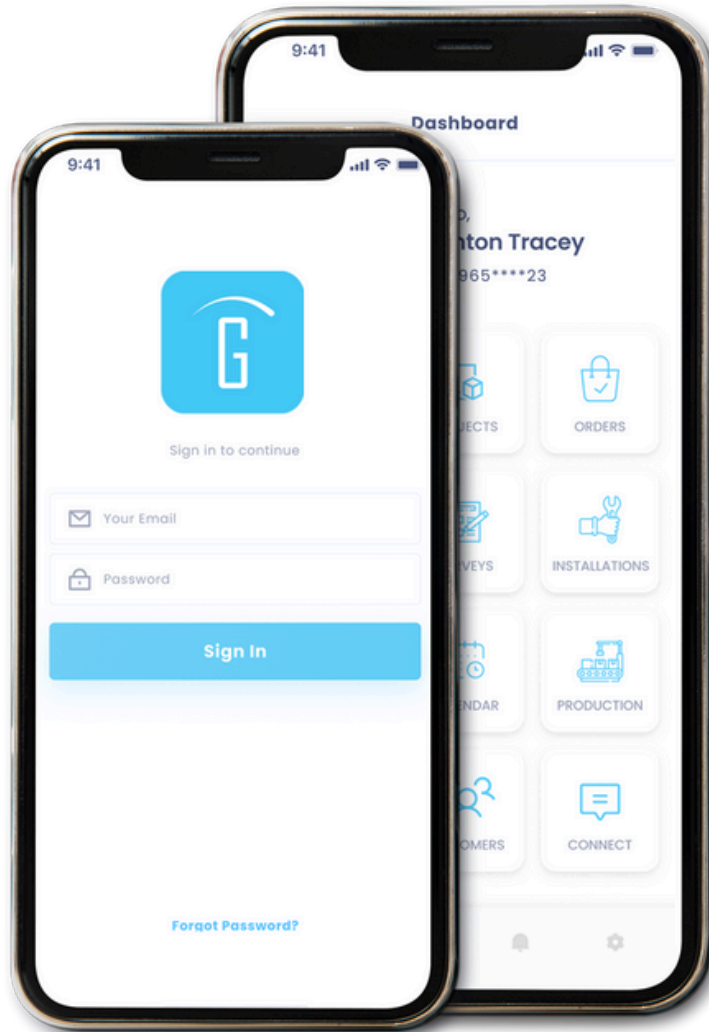

Introducing GlidelineGO – the ultimate system designed to streamline your glazing order management process. With GlidelineGO, customers and trade partners can effortlessly create, track, and manage orders, while enjoying the convenience of approving drawings and making payments directly within the app.

Efficiency and ease-of-use are at the heart of GlidelineGO. Whether you're an architect, contractor, or glazing professional, this powerful app empowers you to take control of your glazing projects, ensuring a seamless experience from start to finish.





GLIDELINE

ARCHITECTURAL GLAZING SYSTEMS